

TOP

TANKS SHOWN FOR REFERENCE ONLY

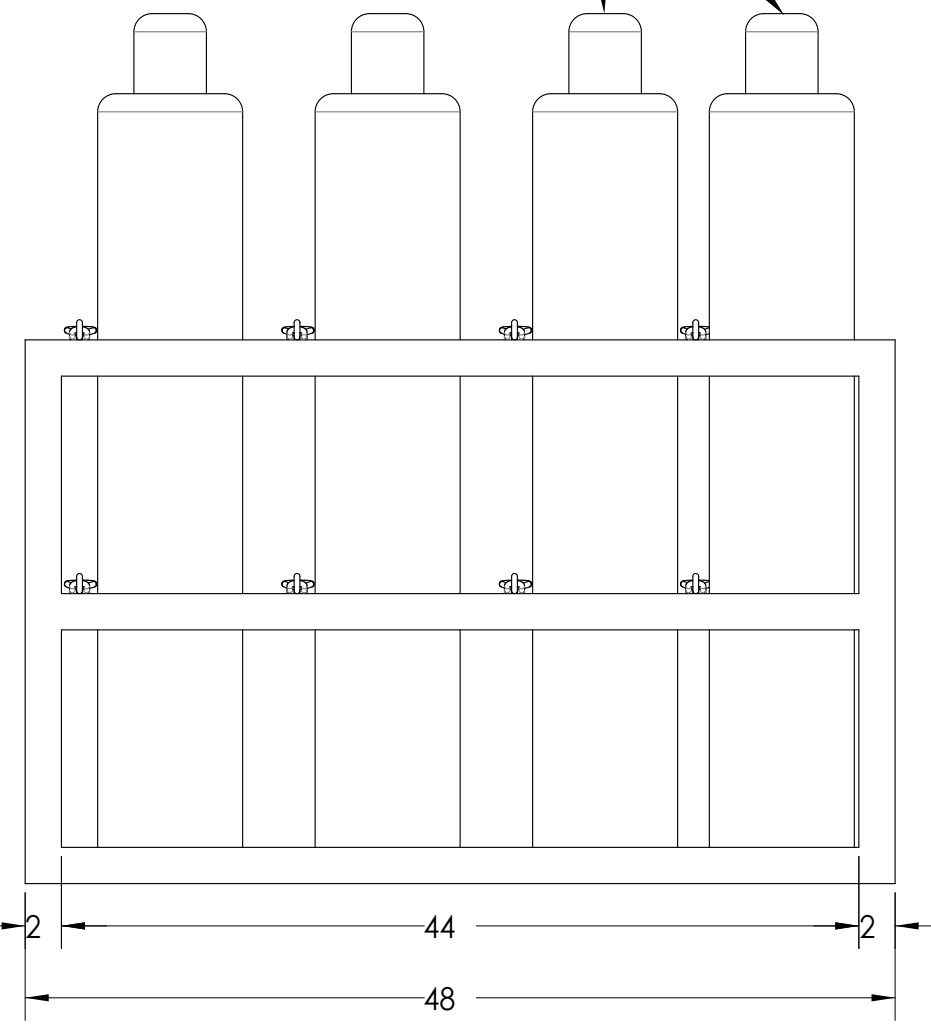

RIGHT

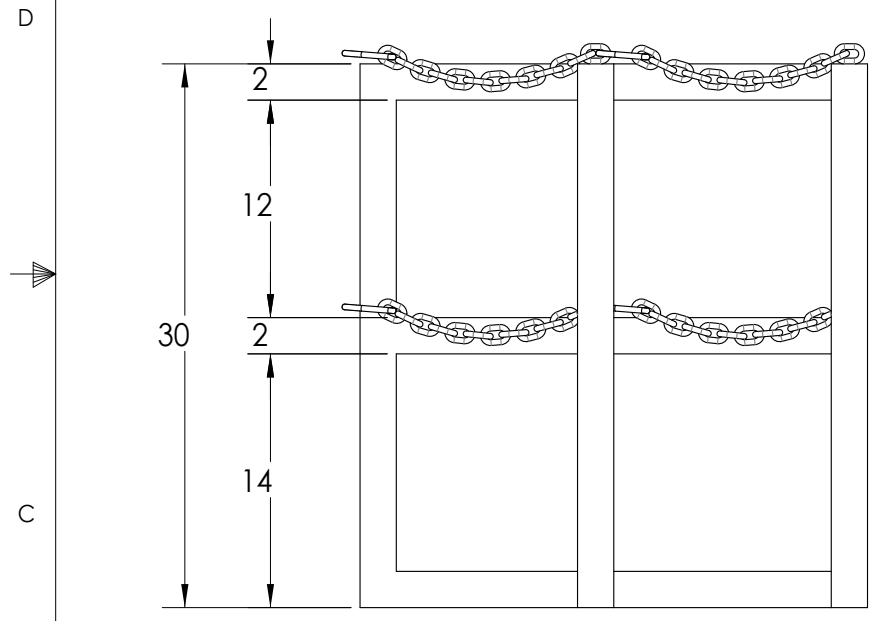

FRONT

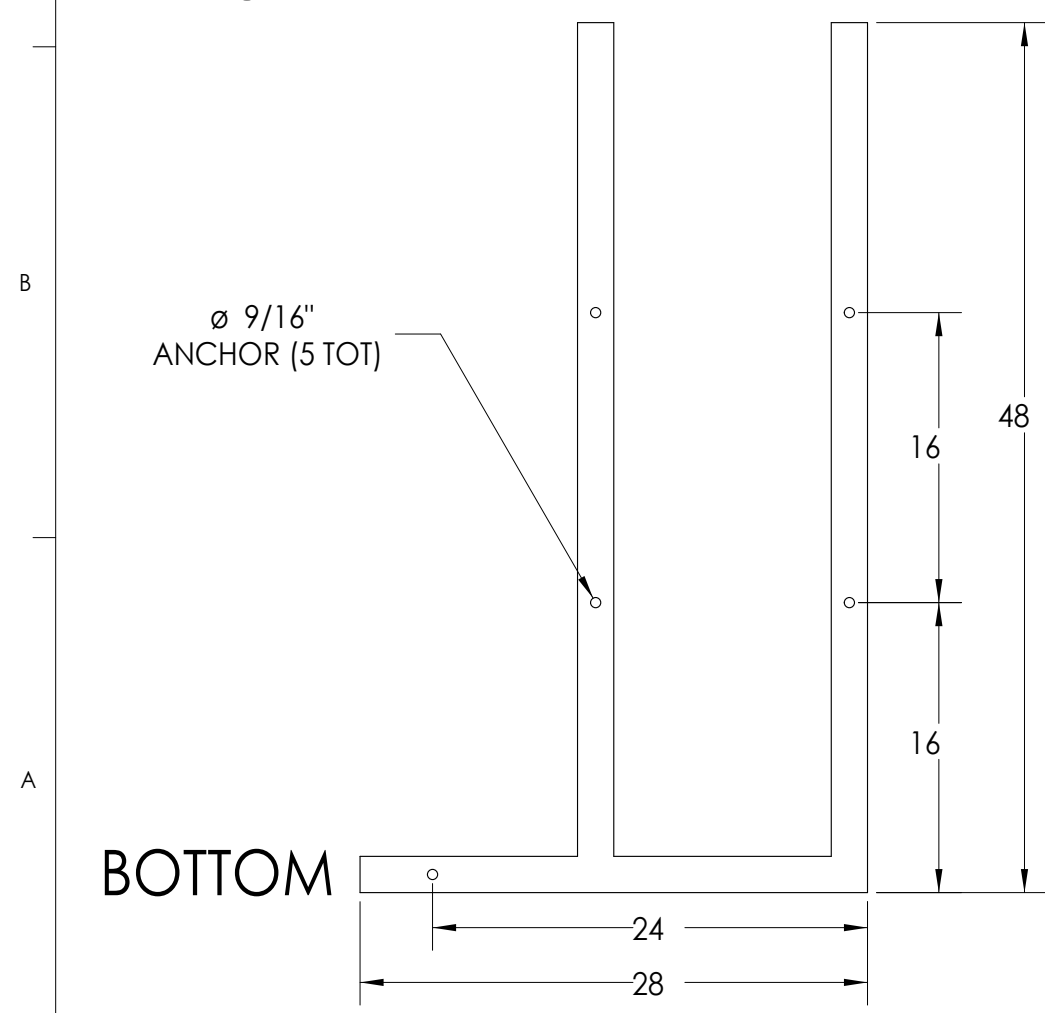

BOTTOM

NOTE: CHAINS REMOVED FOR CLARITY

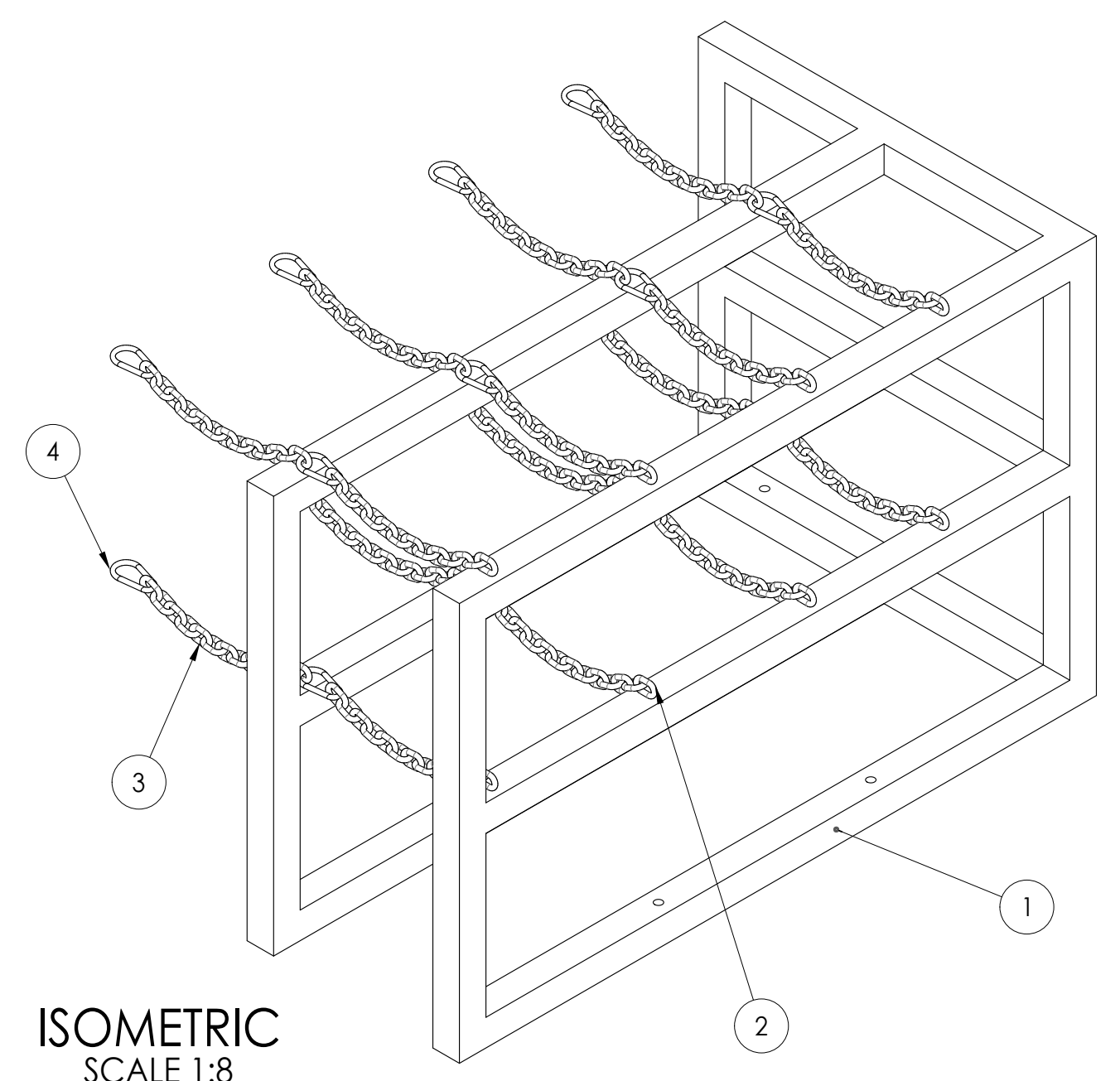

ISOMETRIC SCALE 1:8

ITEM NO.	MATERIAL	DESCRIPTION	QTY.
1	HSS 2" X 2" X 1/8" (NON OPA VERSION) HSS 2" X 2" X 1/4" (OPA VERSION)	HSS STEEL FRAME CUT AND WELDED TO RACK SIZE	1
2	5/16" STEEL WELDED LINK CHAIN (1,900 LBS LOAD RATING)	5/16" SINGLE WELDED LINK WELDED TO RACK FRAME	16
3	5/16" STEEL WELDED LINK CHAIN (1,900 LBS LOAD RATING)	5/16" STEEL WELDED LINK CHAIN CUT TO SIZE	16
4	5/16" STEEL CARABINER HOOK (520 LBS LOAD RATING)	5/16" STEEL CARABINER	16

**PROPRIETARY AND CONFIDENTIAL**  
THE INFORMATION CONTAINED IN THIS DRAWING IS THE SOLE PROPERTY OF <INSERT COMPANY NAME HERE>. ANY REPRODUCTION IN PART OR AS A WHOLE WITHOUT THE WRITTEN PERMISSION OF <INSERT COMPANY NAME HERE> IS PROHIBITED.



UNLESS OTHERWISE SPECIFIED:		NAME	DATE
DIMENSIONS ARE IN INCHES			
TOLERANCES:			
FRACTIONAL ±			
ANGULAR: MACH ±	BEND ±		
TWO PLACE DECIMAL ±			
THREE PLACE DECIMAL ±			
INTERPRET GEOMETRIC TOLERANCING PER:			
MATERIAL			
FINISH			
NEXT ASSY	USED ON		
APPLICATION			
DO NOT SCALE DRAWING			

TITLE:		
<b>MODEL 4D2W-R</b>		
SIZE	DWG. NO.	REV
<b>C</b>	<b>4D2W-R</b>	
SCALE: 1:10	WEIGHT:	SHEET 1 OF 1