

TOP

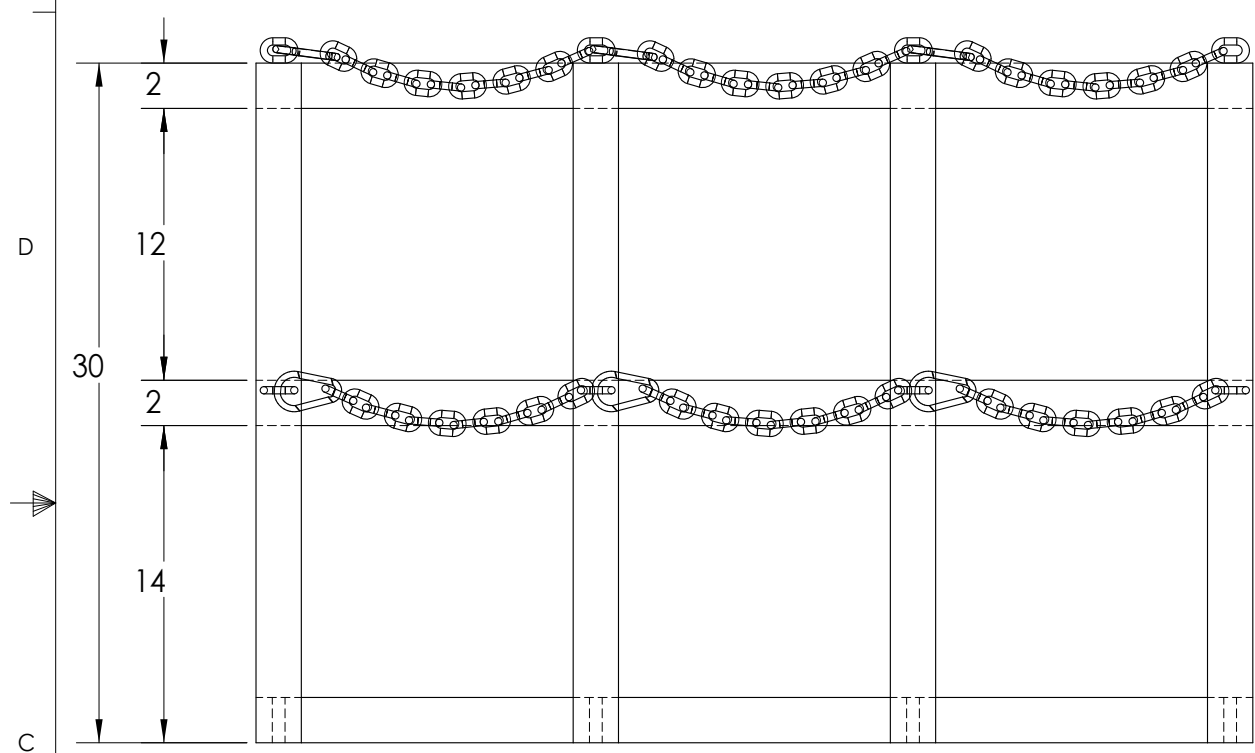

FRONT

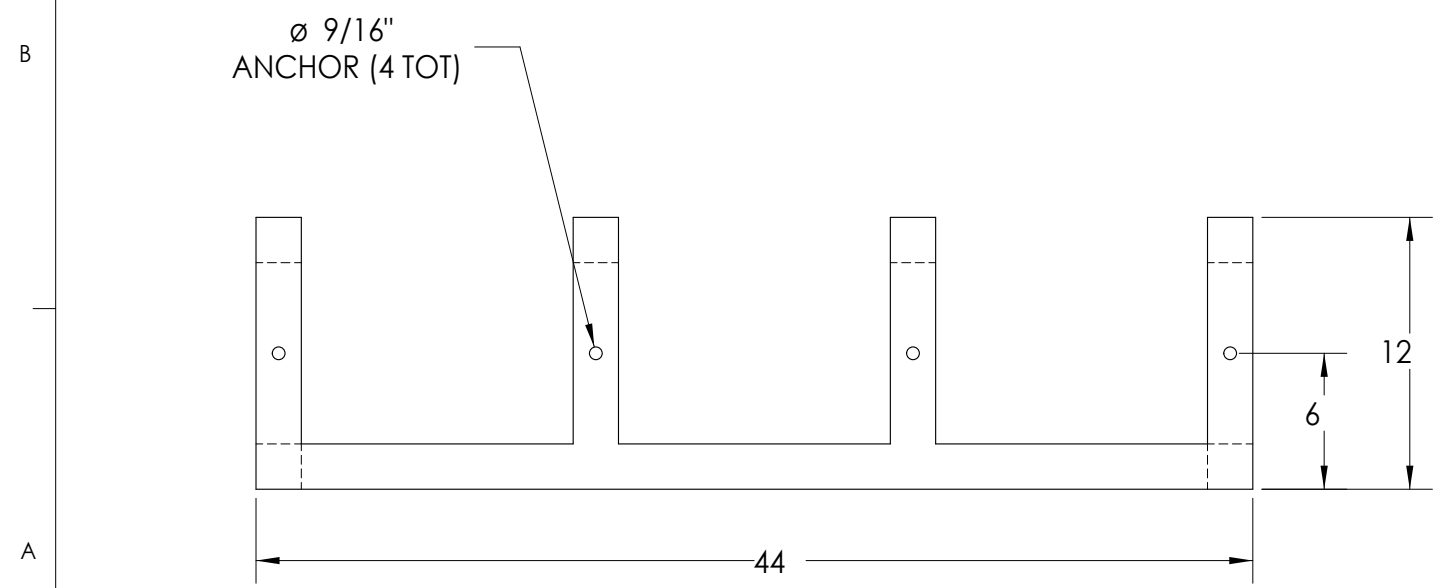

BOTTOM

NOTE: CHAINS REMOVED FOR CLARITY

TANK SHOWN FOR REFERENCE ONLY

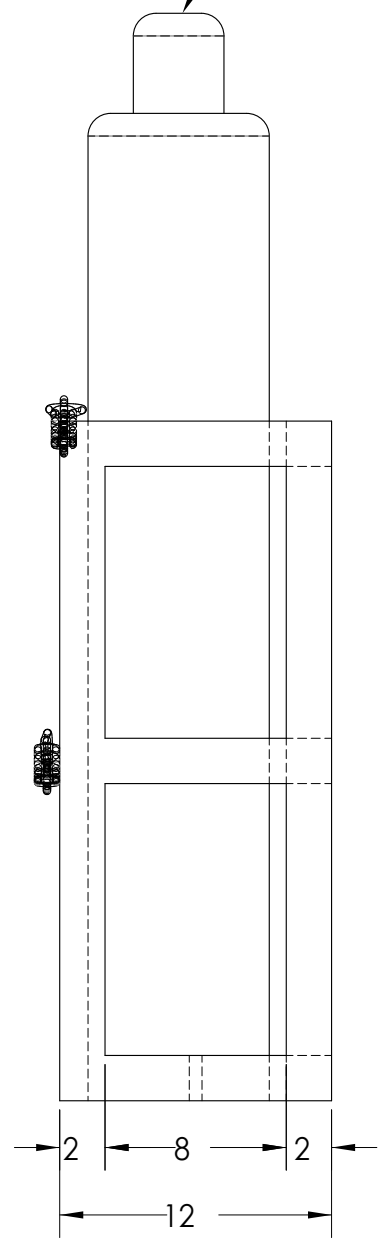

RIGHT

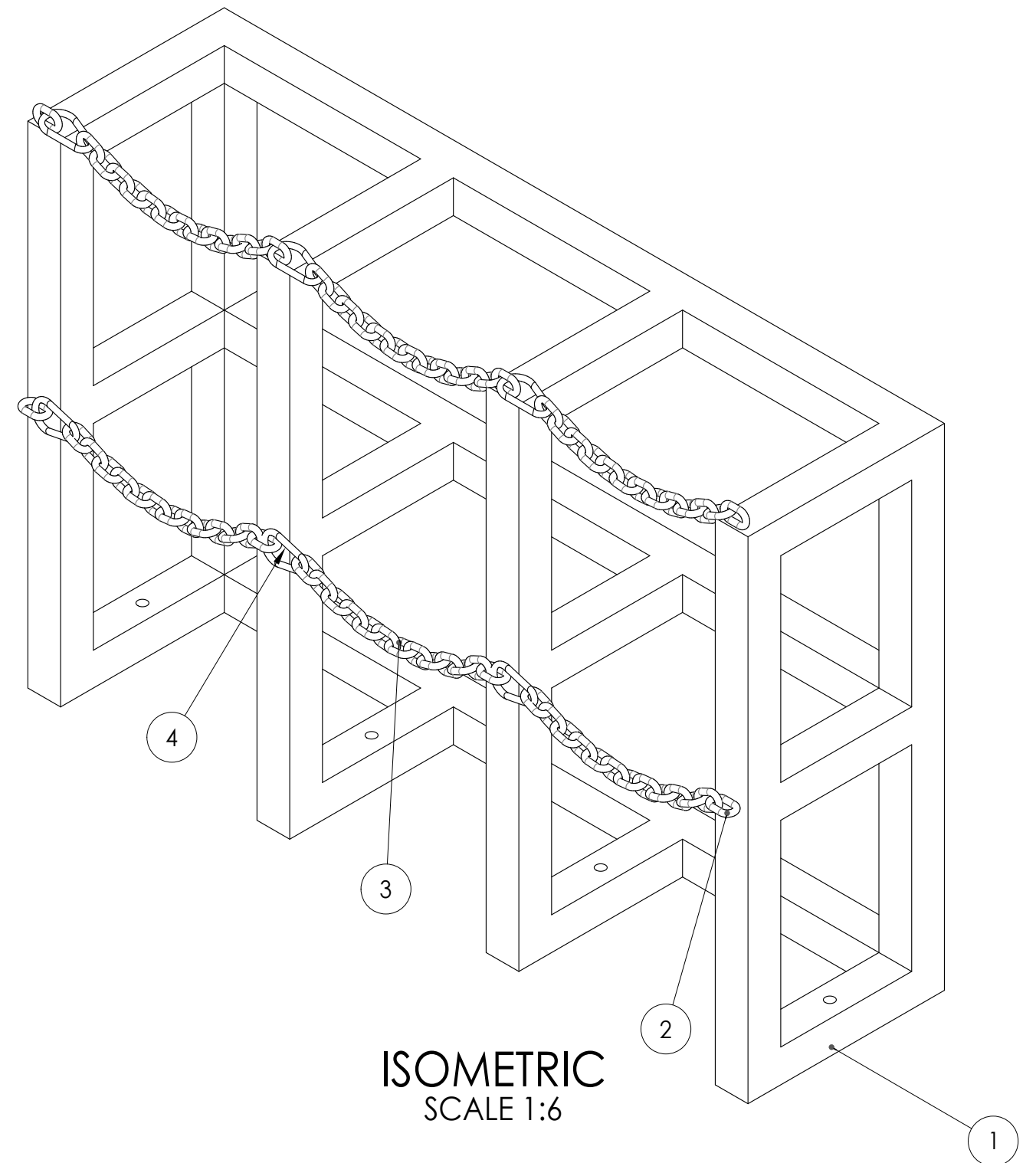

ISOMETRIC SCALE 1:6

ITEM NO.	MATERIAL	DESCRIPTION	QTY.
1	HSS 2" X 2" X 1/8"	HSS STEEL FRAME CUT AND WELDED TO RACK SIZE	1
2	5/16" STEEL WELDED LINK CHAIN (1,900 LBS LOAD RATING)	5/16" SINGLE WELDED LINK WELDED TO RACK FRAME	8
3	5/16" STEEL WELDED LINK CHAIN (1,900 LBS LOAD RATING)	5/16" STEEL WELDED LINK CHAIN CUT TO SIZE	6
4	5/16" STEEL CARABINER HOOK (520 LBS LOAD RATING)	5/16" STEEL CARABINER	6

**PROPRIETARY AND CONFIDENTIAL**  
 THE INFORMATION CONTAINED IN THIS DRAWING IS THE SOLE PROPERTY OF <INSERT COMPANY NAME HERE>. ANY REPRODUCTION IN PART OR AS A WHOLE WITHOUT THE WRITTEN PERMISSION OF <INSERT COMPANY NAME HERE> IS PROHIBITED.



UNLESS OTHERWISE SPECIFIED:		NAME	DATE
DRAWN			
CHECKED			
ENG APPR.			
MFG APPR.			
Q.A.			
COMMENTS:			
NEXT ASSY	USED ON		
APPLICATION		DO NOT SCALE DRAWING	

TITLE: <b>MODEL 1D3W</b>		
SIZE <b>C</b>	DWG. NO. <b>1D3W</b>	REV
SCALE: 1:8	WEIGHT:	SHEET 1 OF 1