

8 7 6 5 4 3 2 1

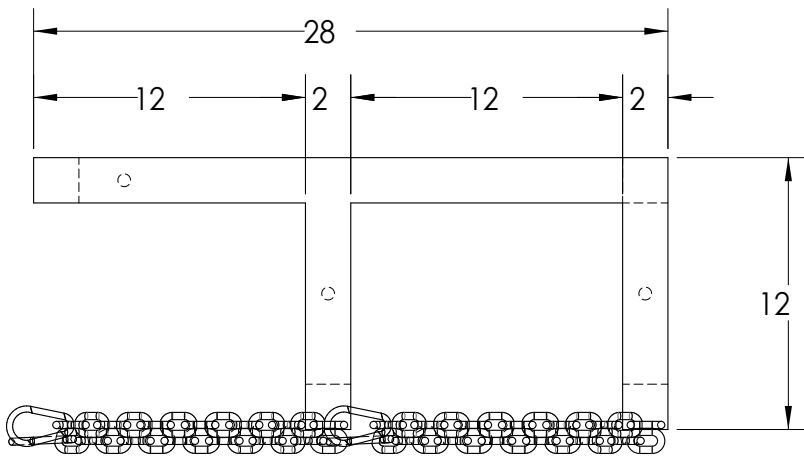

TOP

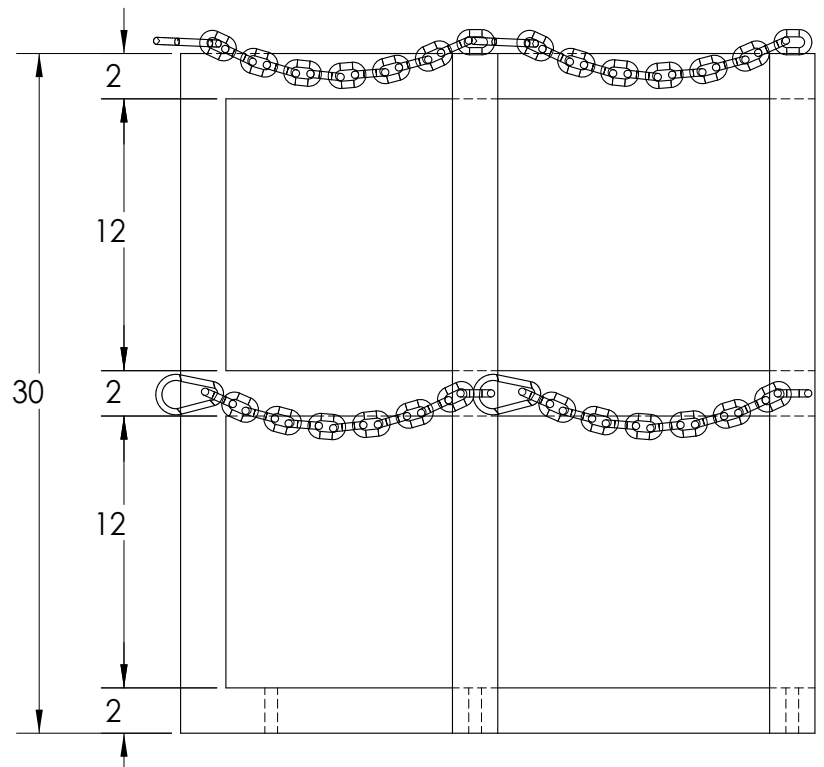

FRONT

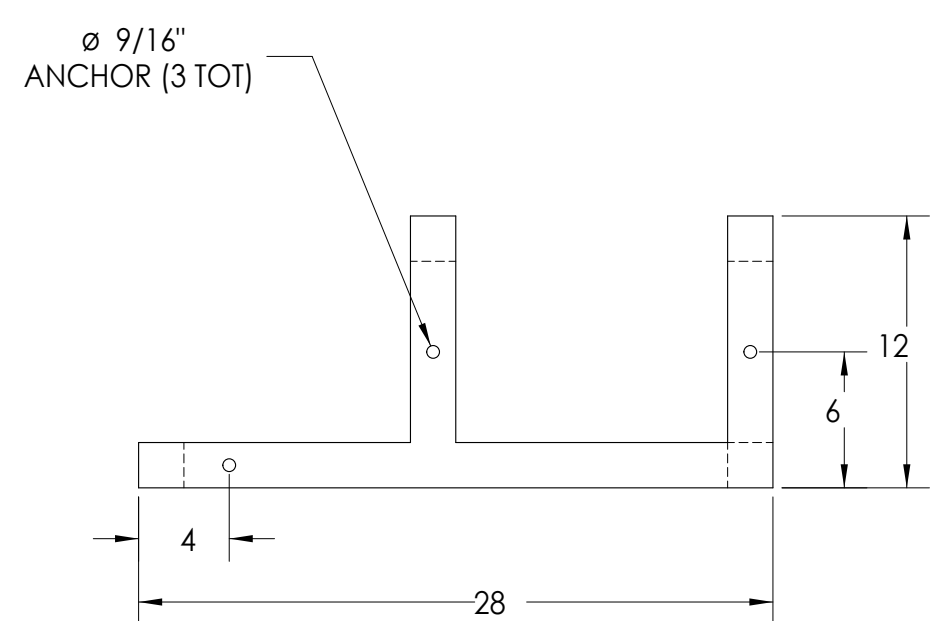

BOTTOM

NOTE: CHAINS REMOVED FOR CLARITY

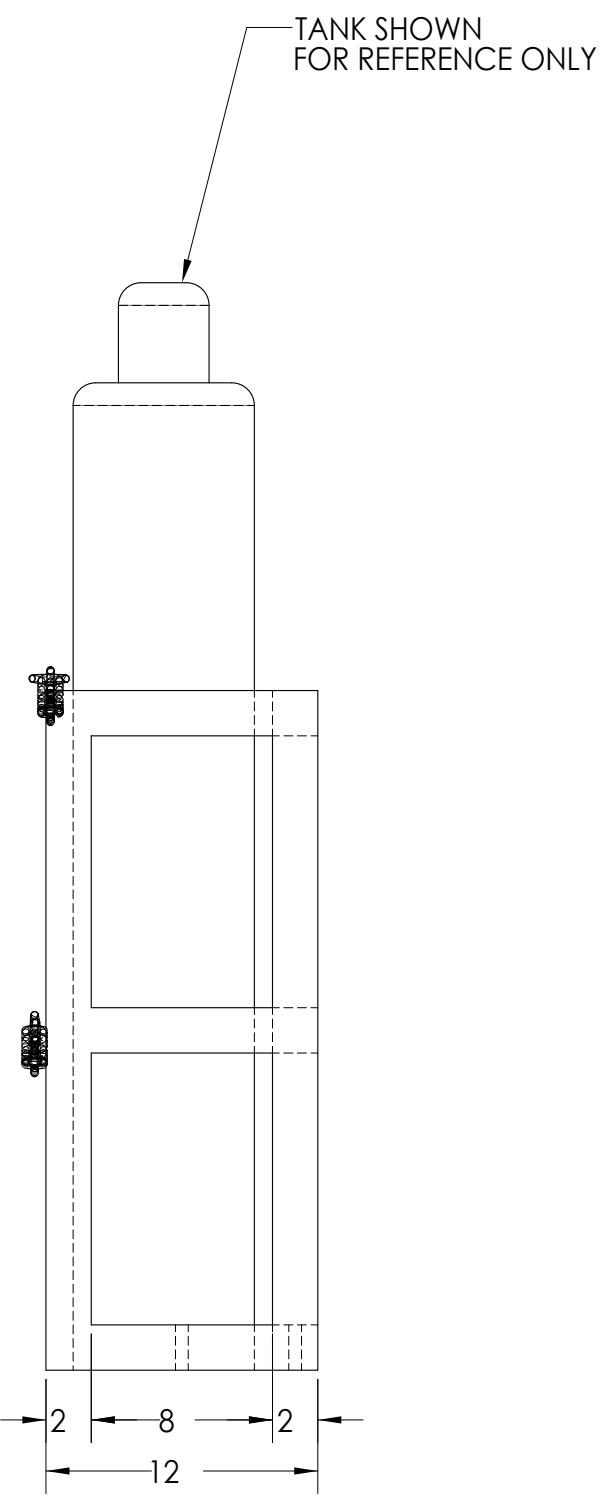

RIGHT

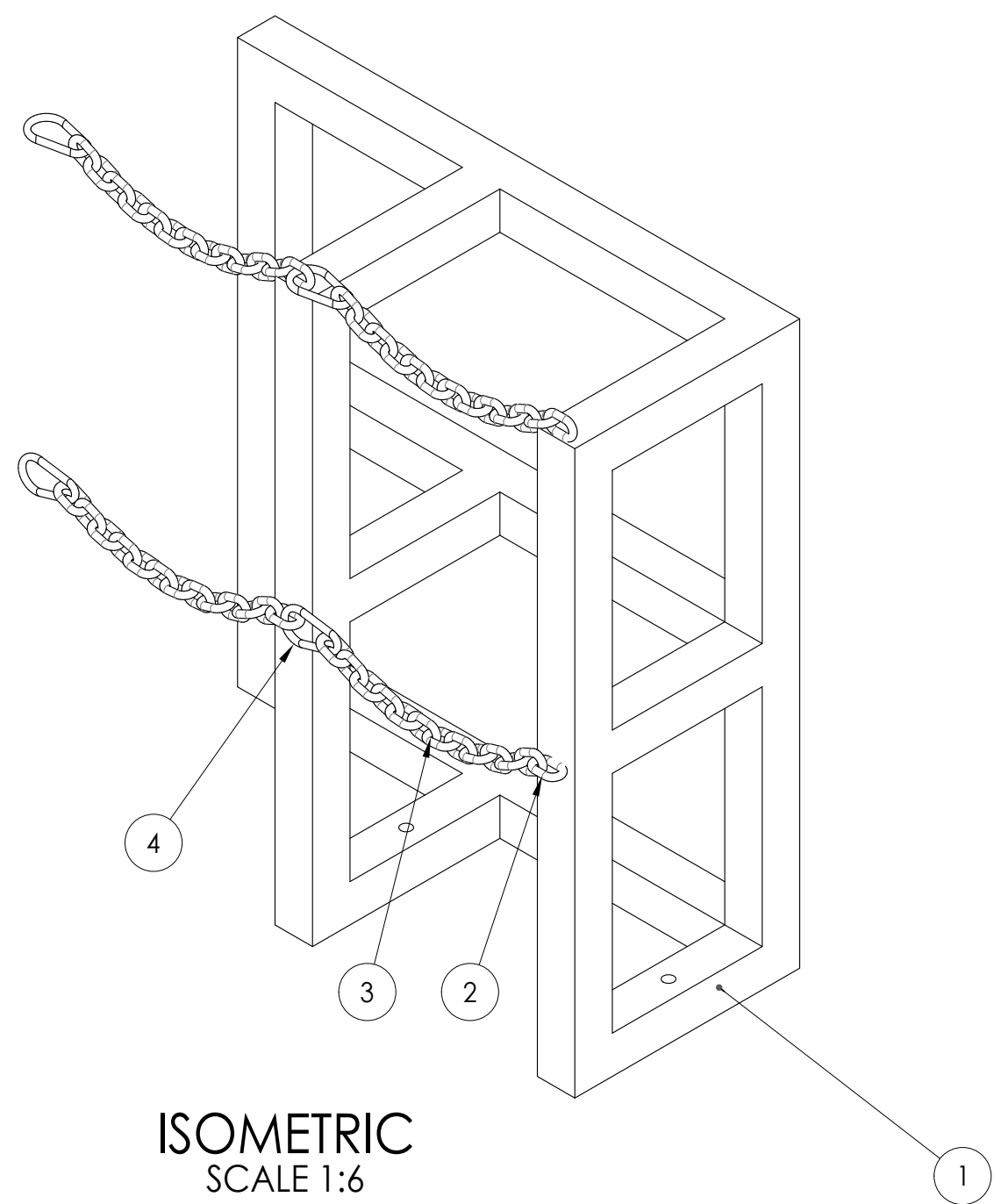

ISOMETRIC
SCALE 1:6

ITEM NO.	MATERIAL	DESCRIPTION	QTY.
1	HSS 2" X 2" X 1/8"	HSS STEEL FRAME CUT AND WELDED TO RACK SIZE	1
2	5/16" STEEL WELDED LINK CHAIN (1,900 LBS LOAD RATING)	5/16" SINGLE WELDED LINK WELDED TO RACK FRAME	4
3	5/16" STEEL WELDED LINK CHAIN (1,900 LBS LOAD RATING)	5/16" STEEL WELDED LINK CHAIN CUT TO SIZE	4
4	5/16" STEEL CARABINER HOOK (520 LBS LOAD RATING)	5/16" STEEL CARABINER	4

PROPRIETARY AND CONFIDENTIAL
THE INFORMATION CONTAINED IN THIS DRAWING IS THE SOLE PROPERTY OF <INSERT COMPANY NAME HERE>. ANY REPRODUCTION IN PART OR AS A WHOLE WITHOUT THE WRITTEN PERMISSION OF <INSERT COMPANY NAME HERE> IS PROHIBITED.



UNLESS OTHERWISE SPECIFIED:		NAME	DATE
DIMENSIONS ARE IN INCHES			
TOLERANCES:			
FRACTIONAL ±			
ANGULAR: MACH ± BEND ±			
TWO PLACE DECIMAL ±			
THREE PLACE DECIMAL ±			
INTERPRET GEOMETRIC TOLERANCING PER:		COMMENTS:	
MATERIAL			
FINISH			
NEXT ASSY	USED ON		
APPLICATION		DO NOT SCALE DRAWING	

TITLE:		
MODEL 1D2W-R		
SIZE	DWG. NO.	REV
C	1D2W-R	
SCALE: 1:8	WEIGHT:	SHEET 1 OF 1

8 7 6 5 4 3 2 1