

# Amico Alert-2 Sensor Module



## Features:

- Computer calibrated
- Interference barrier (frequency interferences)
- Interchangeable with old sensors
- Temperature compensated
- Sensors can be mounted locally or remotely utilizing 22-gauge shielded, twisted pair wiring up to 5,000 ft. [1,524 m]
- Smallest sensor in the industry
- Pressure on both gas and vacuum sensors shall not exceed 250 psi
- Includes a gas specific DISS fitting

## General Specifications:

The Sensor Module shall be complete with a five-year warranty.

The Sensor Module shall contain the transducer which is connected, either remotely or locally, to the supply pipe. This transducer shall transmit, by means of conversion into a digital signal, the actual line or vacuum pressure on the display of its respective Area Alarm Module.

Each sensor shall be clearly labeled and color coded for the gas or vacuum being monitored. The sensor module shall contain a gas specific DISS fitting to ensure that the sensor is connected to its corresponding gas. As well, all sensors shall be computer calibrated for the specific gas shown on the sensor housing.

If the sensor is not connected at all or not to the appropriate gas display module, an error message (EO1 or EO2, respectively) will be displayed. Whether connected locally or remotely, when the sensor module is first powered up the LED flashes in red.

The sensor module shall be provided with a 6" (0.1 m) twisted pair of wires. One wire shall be red (positive) and attached to the terminal "Sensor +" while the other wire shall be black (negative) and attached to the terminal "Sensor -". The terminal block on the display module is clearly marked for the proper connection of the sensor wires. Should there be a cable shortage or should polarity be reversed, error code EO6 will appear.

The Sensor Module shall be housed in an anodized aluminum and nickel-plated brass enclosure to act as an interference barrier.

The base of the module shall have a 1/2" [13 mm] conduit connection.

All Amico products comply with NFPA 99 standards.

The alarm is UL listed to U.S. and Canadian safety standards.

# Technical Specifications

**Note:** DISS Demand check valves by 1/4" NPT, supplied with each remote sensor.

Inch  
[mm]

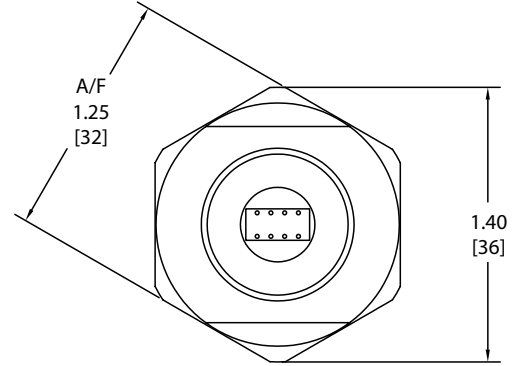
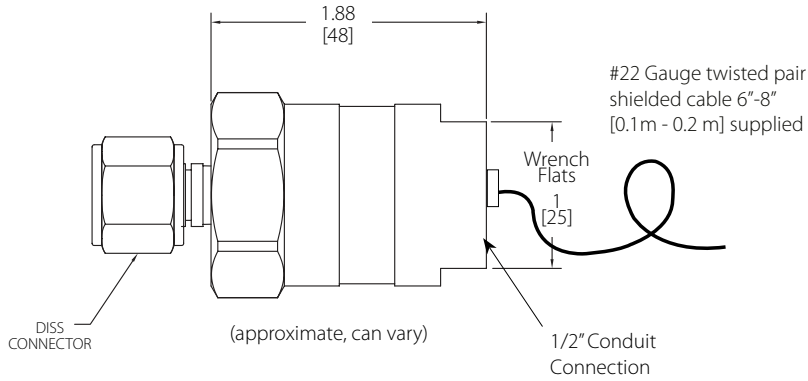

1/2"-14 NPSM [13]  
(see Thread Specs.)

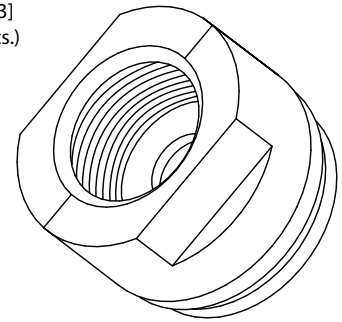

## Model Numbers

### A2P-SENS-L-GAS

**The "L" defines the Language:**

- U = English (NFPA) Oxy, Air, Vac and WAG only
- E = English (CSA/ISO)
- F = French (CSA/ISO)
- S = Spanish (NFPA)

**The "XXX" defines the Gas:**

- Oxygen = OXY
- Medical Air = AIR
- Nitrous Oxide = N2O
- Carbon Dioxide = CO2
- MedVac<sup>1</sup> = VAC
- Waste Anesthetic Gas Disposal (NFPA) = WAG
- Anesthetic Gas Scavenging System<sup>1</sup> (CSA) = AGS
- Instrument Air = IAR

<sup>1</sup>Please see note above